

# COMANCHE<sup>®</sup>

## **DART for Test Point Specification** **Remote Monitoring and Control System** **Software & Hardware Specification**

### **PURPOSE AND SCOPE**

The following specification details a **Comanche<sup>®</sup> Dart for Test Point - Remote Monitoring and Control System (RMCS)** tailored for Cathodic Protection Systems for the oil, gas and utility industries which would include production wells, gathering systems, pipelines, tank farms, and petrol-service stations with specific emphasis on corrosion mitigation but not limited to this application.

This **Comanche<sup>®</sup> Dart for Test Point (RMCS)** specification covers the requirements for the RMCS web based software, RMCS hardware, communication between sites and the web based Data Center and the continuing requirements for technical support and training of **The Company** personnel.

This **Test Point RMCS system** shall be used to automatically monitor test points associated with cathodic protection systems and any other process that **the end user** determines applicable.

As an example for Cathodic Protection test point applications, this shall include but not be limited to, the ability to monitor reference electrodes, control relays to monitor Off potential and depolarization readings, monitor resistance bonding points, monitor DC and AC corrosion current density, monitor casing to carrier shorts, et cetera. Also, the monitoring system shall be able to send alarms when the parameters are out of the specified value or range.

As an example for other applications, this shall include but not be limited to, the ability to monitor tide levels, monitor and/or control tank levels, monitor and/or control pressure, temperature, flow rates, valves, alarm systems, security systems, lighting systems as well as petroleum viscosity, et cetera.

### **SOFTWARE FEATURES**

#### **OPERATING SYSTEM**

The **Comanche<sup>®</sup> Web-Based Data Center and Software** for **Remote Monitoring and Control Systems (RMCS)** shall be accessible from any operating system including but not limited to Windows, Apple OS, Android, and IOS that has access to the Internet.

The System shall be used by individuals familiar with the Internet but **shall not require any specialized programming skills.**

For customers that prefer to use a private network, please refer to the Comanche Remote Monitoring and Control System for Private Networks.

#### **OPERATING METHOD**

The System shall work **automatically** without requiring the attention or time of **The Company** personnel. Once set up, the monitoring and alarm functions shall operate automatically without requiring **The Company** personnel to be present. The remote monitoring and control shall automatically notify personnel via text messages or e-mails in a sequence that shall be determined by **the end user**.



## SYSTEM GRAPHICS

The System shall communicate technical processes through visual images, maps, drawings and photographs. The System's visual presentation shall be able to import files in any current graphics format to produce the computer's on-screen graphical interface. Access to the specific processes or values shall be made directly from the image.

The Data Center Software shall have an integrated mapping system that (if enabled by the end user) shall display an icon of each Remote Monitoring Unit in its geographical position as per its GPS coordinates.

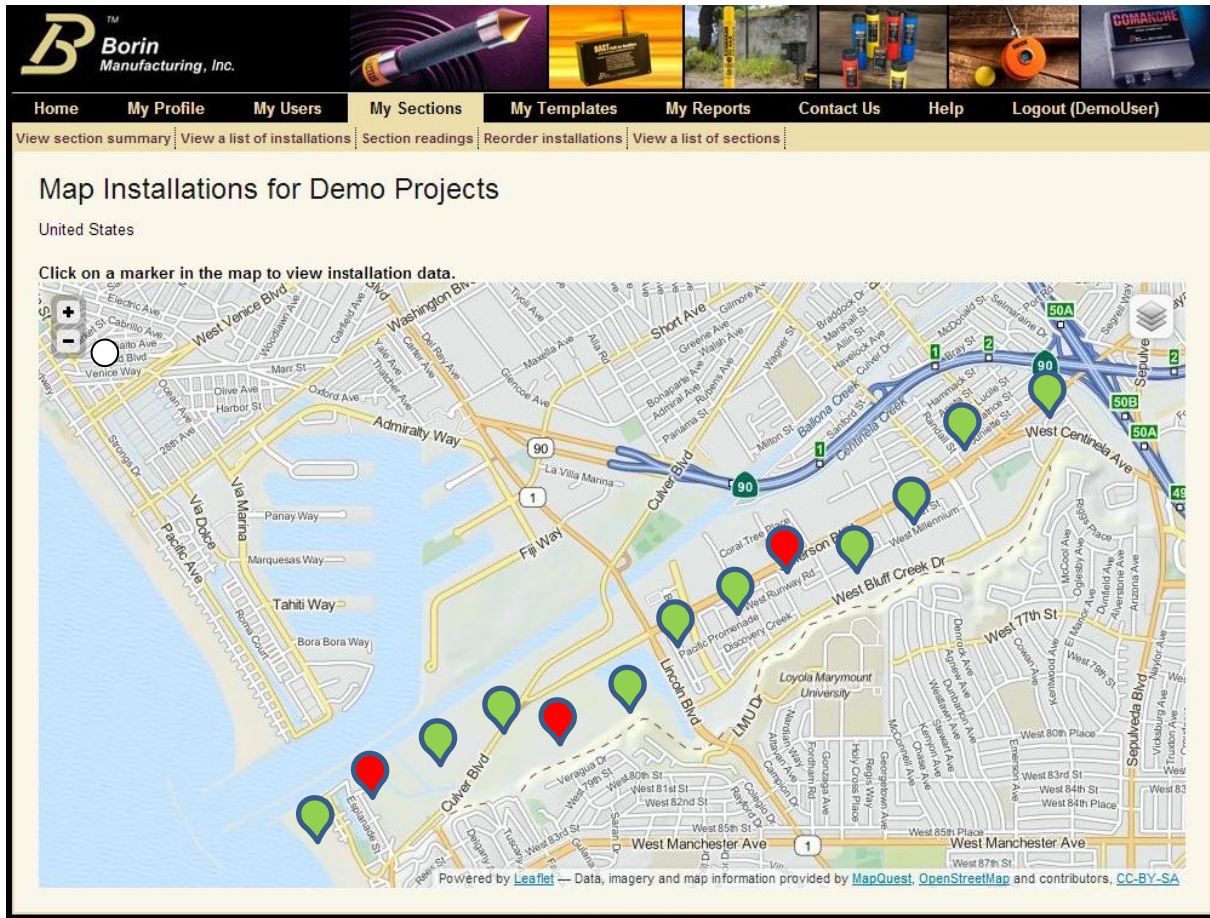

## DATA STORAGE CAPACITY

The system shall have unlimited data storage capacity and should have automatic back up procedures of historical data.

## ALARM MANAGEMENT SYSTEM

The alarm management System shall automatically initiate calls from the remote installations to the Comanche Data Center.

Analog monitoring channels shall have full **alarm** capabilities.

Alarms detected by the hardware module, at the site, shall generate automatic messages to the Comanche Data Center.

The **Alarm Management System** shall provide **an alarm screen** to document actions taken, and by whom, that shall automatically become part of the permanent record of that event.

## AUTOMATIC SURVEILLANCE

The **System** shall initiate, at a user defined frequency, the Comanche Data Center to automatically and systematically contact the field hardware modules to monitor the values and control processes and to download data at predetermined intervals.

The screenshot displays the Borin Manufacturing, Inc. web interface. At the top, there is a navigation menu with options: Home, My Profile, My Users, My Sections, My Templates, My Reports, Contact Us, Help, and Logout (DemoUser). Below the menu is a breadcrumb trail: Details | Readings archive | Graph readings | Advanced logging | Device settings | Channel settings | Alarms | History | Cyclic Interruption | Off Potential | Section summary. A yellow notification box states "Channel settings updated!". The main heading is "Channels Update for Culver - Del Rey". Below this, it shows "Demo Projects United States" and a "Refresh Page" button. A table displays channel data, with a note "Displaying 1-4 of 4 result(s)".

Channel	Name	Type	Last Reading	Last Value	Range	Power-up Value	Command	Alarm Low	Alarm High	Alarm Triggered	Alarm Value	Clear Alarm	Action Taken
2	Pipe to Soil Potential RE2	Analog Monitor	2013-04-23 13:17:26.935 PDT	1.03 Volt	1 .. 5 Volt								
3	AC current	Analog Monitor	2013-04-23 13:17:27.171 PDT	0.014 mA	0 .. 0.1 mA								
4	Cupon Potentail	Analog Monitor	2013-04-23 13:17:27.406 PDT	0.8 Volt	0.8 .. 0.85 Volt								
26	Cupon Interrupter	Digital Control	2013-04-23 13:17:28.583 PDT	On		none	Set						

Below the table is a button labeled "Get Update to Latest Readings". At the bottom of the page, it says "Copyright © 2013 by BORIN".



## COLOR CODED STATUS ICONS

The System shall provide a “**Graphical Link**” for all of the incoming messages. This means that status icons will be displayed on the “**Visualizations**” (graphical links) as well as the software input and column screens.

Each message on this incoming screen shall have a direct link to a specific piece of equipment and this link shall be graphically illustrated.

The system shall provide Installation detail records about the equipment which shall include installation notes, current values and diagnostic data relating to performance of the equipment.

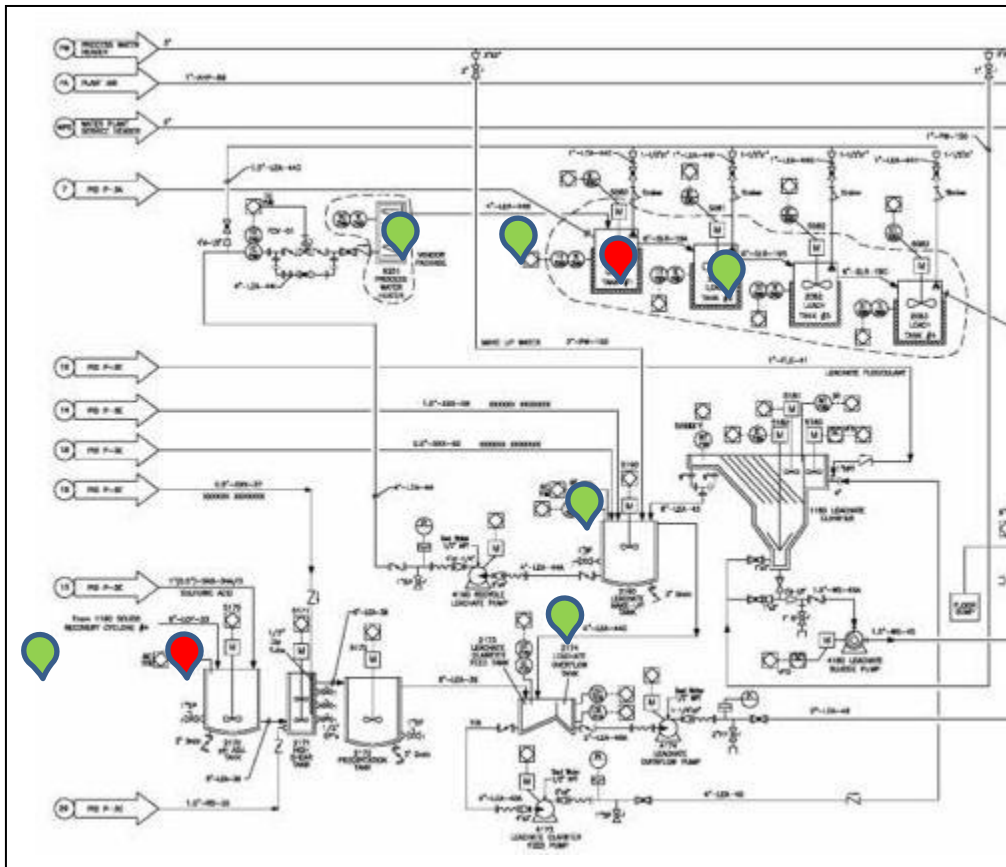

## REPORTS

The system shall provide a summary screen to visualize the most critical variables for the entire system including all the installations as grouped by the end user.

The system shall provide multiple screens to view the data with filter and sort features to generate reports right from the Data Center.

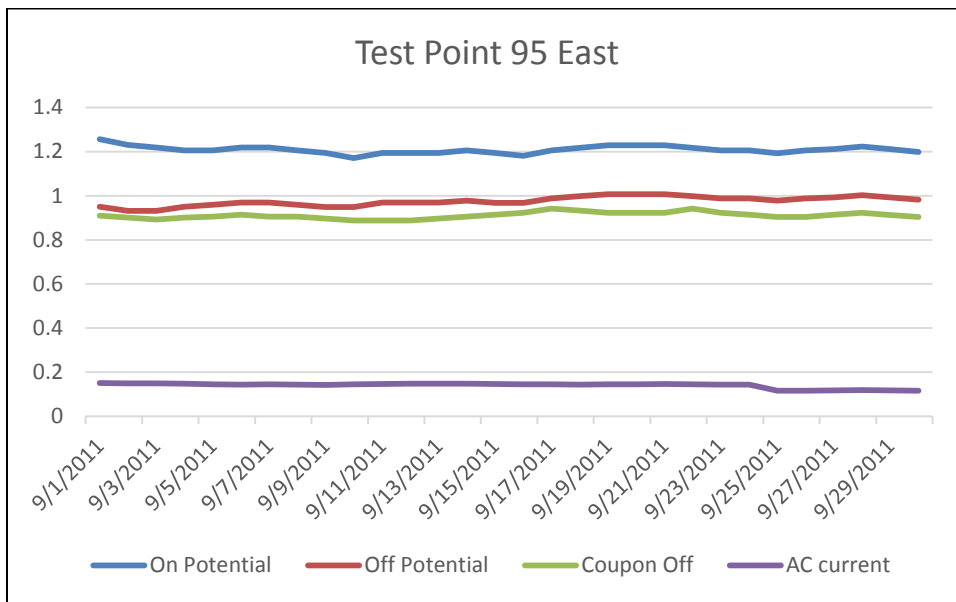

## REMOTE UNIT FUNCTIONALITY

The management of the field hardware through the software shall consist of the following three elements:

**Monitoring** – The system shall have the full capability of monitoring **Automatically** analog functions of any field equipment that provides an electrical interface. This would include but not be limited to: On and Off structure to soil potential, instant Off potential, depolarization potential (100 mV shift criterion), IR drop free readings, DC and AC current density, temperature, resistance bonding points, native coupon potential, pressure, smoke alarms, burglar alarms, lighting systems, on-off valves, control valves, flow, density, humidity, gates, doors, soil resistance, soil pH, strain gauges, tank levels, boiler pressure, water & hydrocarbon leak detectors, electrical rails, transmission lines, pipeline crossing influence, et cetera.

**Control** – The system shall have the full capability of **Automatically** controlling a relay or switch. This would include but not be limited to: relay for Off potential and depolarization readings, smoke alarms, burglar alarms, lighting systems, on-off valves, gates, doors, structure to soil potentials, et cetera.

## DIAGNOSTICS TOOL

**Diagnostics** – The system shall have the full capability of performing diagnostics on remote field equipment to determine their operational status. This would include but not be limited to: Instant Off and On IR Free Potentials using the DIN 50925 standard technology, induced AC voltage, AC mitigation integrity, Current Density, DC protection current, bond current (bi-polar direction), 100 mV shift criterion, Line Crossing Integrity, Casing to Carrier Integrity, Flange Insulation Integrity, resistance bonds, current for sacrificial anodes, Off potential for sacrificial anodes.

The System shall have the capacity to zoom into unscheduled past events/alarms for analysis and graph high frequency readings (up to 15 s) for a defined period of time to facilitate assessment and troubleshooting of several variables simultaneously.

## INSTANT OFF AND DEPOLARIZATION FUNCTION

The System shall take Off Potential readings with time parameters configurable in milliseconds.

The System shall compare the Off Potential reading to a user predefined Off Potential Standard. If the Off Potential is lower than the standard, the system shall take a second Off Potential reading (depolarization) after a user defined wait time.

- The **Test Point RMU shall** provide sacrificial anode to structure current readings, as well as, instant Off & On IR Free readings in compliance with the DIN 50925 standard using a 1 ampere, dual contact, zero power latching relay.
- The **Test Point RMU's** 50 mA, dual contact, zero power latching relay feature provides the ability to apply the System to a broad range of applications not limited to corrosion.

**Borin Manufacturing, Inc.**

Home | My Profile | My Users | My Sections | My Templates | My Reports | Contact Us | Help | Logout (DemoUser)

Details | Channels update | Readings archive | Graph readings | Advanced logging | Device settings | Channel settings | Alarms | History | Cyclic Interruption | Section summary

### Off Potential Details for Culver - Del Rey

Fields with \* are required.

Start Frequency \*

Start Time \*  (in installation's time zone)

Off Channel \*

Off Potential Wait Time \*  ms

Reference Channels \*  Rectifier Voltage Output  
 Rectifier Current Output  
 Pipe to Soil Potential RE 1  
 Cupon Potential

Threshold Channel

Threshold  Volt (Valid range: 0.9 .. 0.95 Volt)

Depolarization Wait Time  s

Off Potential

-----

[Edit Off Potential Settings](#)

[Remove Potential Settings](#)

-----

[View Off Potential Readings](#)

[Graph Off Potential Readings](#)

Copyright © 2013 by BORIN

## PERSONNEL MANAGEMENT SYSTEM

The **Comanche® Remote Monitoring and Control System (RMCS)** shall provide for the ability to organize **company** personnel, that are required to participate in this program, at all levels of the company, in a manner that shall allow alarm messages to be sent **Automatically** to the responsible person, or persons, in the correct geographical locations of the country.

The **Personnel Management Software Module** shall maintain a data bank of personnel, and be able to send text messages or e-mails to a person as predetermined by **the end user**. The messages sent shall include information regarding the incident causing the alarm.

## USER RECORDS HISTORY

The system shall keep record of all changes on alarms clearing and changes to settings for installations and channels made by each user. The system shall allow to filter and sort historic user records for analysis or report generation as determined by the end user.

These messages shall become **permanent records**.

View History for 10.64.0.22

Demo Projects  
United States

Displaying 91-100 of 203 result(s).

Date	Type	Name	Action	Original Value	New Value	Action By
2012-12-30 17:20:58	Channel	Digital Control (27)	change monitor	0	1	DemoUser
2012-12-30 17:20:58	Channel	Digital Control (27)	change alarm_high	0.000	1	DemoUser
2012-12-30 17:20:58	Channel	Digital Control (27)	change alarm_low	0.000	1	DemoUser
2012-12-30 16:43:12	Installation	10.64.0.22	change latitude	0.000000	39.957649	DemoUser
2012-12-30 16:43:12	Installation	10.64.0.22	change longitude	0.000000	-75.337487	DemoUser
2012-12-30 16:43:04	Settings	lon	change value		-75.337487	DemoUser
2012-12-30 16:43:04	Settings	lat	change value		39.957649	DemoUser
2012-12-30 15:36:57	Installation	10.64.0.22	change longitude	0.000000		DemoUser
2012-12-30 15:36:57	Installation	10.64.0.22	change latitude	0.000000		DemoUser
2012-12-30 15:36:57	Settings	time_zone	change value	America/Los_Angeles	America/New_York	DemoUser

Go to page: < Previous 5 6 7 8 9 10 11 12 13 14 Next >

Copyright © 2013 by BORIN

## SECURITY

The system shall have a **security system** working continuously on **three levels**.

The **FIRST** level shall be **software driven** and have a multiple level password structure which shall enable personnel to have differing levels of system access and control.

The **SECOND** level shall be **software driven** requiring a high level data encryption system to ensure the integrity of the information.

The **THIRD** level shall be **communications directed** through the software preventing a third party computer access via any communications system.



### **DATA COMPATIBILITY**

The system's data shall be compatible with major data base and spreadsheet programs. Data shall be able to be downloaded, graphed and manipulated for analysis into programs such as databases and spreadsheets software as well as custom programs.

Each Test Point RMU shall have a unique identification number which shall be integrated into the database and should allow the end user to identify each unit with detailed information that can include, (if set by the end user) its geographic coordinates. In areas with high concentration of test points, the end user shall be able to easily access the test point details for seamless identification.

### **TECHNICAL SUPPORT & TRAINING**

Technical Support shall be provided on a continuing basis to *the end user* at **NO CHARGE**.

This technical support shall be available 24 hours a day and feature "**Remote Diagnostic Access**". This **RDA** feature shall allow (only if authorized by the end user) a technical support engineer to access the master station from a remote location while at the same time providing instructions to the *end user* personnel via telephone.

Training Support shall be provided on a continuing basis to *the end user* at **NO CHARGE**.

### **HELP SYSTEM**

The System Web Based Software shall have **on line help files** at all levels of the program. Instructions for all the basic and advanced functions of the software and hardware shall be included.

### **SOFTWARE UPGRADES**

Software has more than 50 man-years of software development time and is always being expanded to stay at the cutting-edge of the state of the art in features and processing efficiency.

## **HARDWARE FEATURES**

---

### **HARDWARE QUALITY**

All remote module hardware shall be manufactured with **military grade components**. No exceptions will be allowed. All plug and play cards shall have gold plated pins and sockets. No exceptions will be allowed.

### **PRIMARY ENCLOSURE**

The primary enclosure shall be high impact plastic colored black or dark gray through the use of carbon black colorant to provide the first level of ultraviolet protection. Additionally, ultraviolet inhibitors shall be used in the manufacture of the primary enclosure. The primary enclosure shall be water, moisture and dust proof to an IP65 rating (Nema 4x). The primary enclosure shall contain only the principal electronics.

The Test Point RMU enclosure shall fit into the "Top Hat" style CP test station for convenient installation in existing test stations.

The Test Point RMU shall at the request of the end user be pre-mounted on a test "Top Hat" style test station and ready for making the connections in the field.



## CHANNELS

The remote modules shall be capable of remote monitoring of analog functions.

All modules can be linked together to work in concert with each other in any combination and in any quantity.

Configuration of all hardware functions shall be done from the master station (no configuring in the **field** shall be required as part of the setup or continued operation of the system).

The **Test Point RMU** shall have the following channel configuration:

- 3 High impedance channels for AC or DC voltages.
- 1 low voltage channel for AC/DC shunt measurements
- 1 relay for Instant Off and Depolarization readings

## CHANNEL SPECIFICATIONS

The Analog channels shall have a 20 meg-Ohm internal impedance and a 60 Hz AC rejection capability and a transient voltage trapping capacity of 2,500 volts.

Other ranges are available on special order for special applications.

The Test Point RMU's relay shall operate at a maximum voltage of 24V and maximum current of 50 mA, and shall be of the type dual contact, zero power latching relay. This feature provides the ability to apply the System to a broad range of applications not limited to corrosion.

For use with Cathodic protection coupons, the Test Point RMU shall have the following user selectable resistors: 25 Ω, 35Ω, 60 Ω, 125 Ω, n.c. (external shunt)

**All** channels shall have "**Full Memory Retention**" capability when power is terminated.

**All** channels shall be capable of taking readings up to every 15 seconds.

**All** channels shall maintain their established settings and protocols in the advent of a power failure or any other high surge electrical condition and **there absolutely shall be no requirement to re-enter any information** as a result of these surges or power failures.

**All** analog channels, shall have the capability of displaying a DIN standard IR-Free reference electrode and showing both its **ON** and **OFF** potential readings.

**All** analog channels, which are intended to monitor reference electrodes, shall have a minimum of twenty (20) meg-Ohms of internal impedance. **There will be no exceptions to this feature.**

## DATA-LOGGING

All of the remote module channel configurations shall have a full featured data-logging capability.

All data accumulated shall be saved in the advent of a power failure or if the remote module is disconnected or shut off.

The data-logger shall record the activity of all its channels that are working simultaneously.

An SD card shall be used to download data-logging results into a computer.

## SYSTEM POWER

The Hardware shall be powered by a replaceable Lithium Battery with 3-5 year life expectancy. Battery life shall be expandable.

Battery enclosure shall be easily accessible for battery replacement and no special tools or skills shall be required. Battery pack shall be replaced by unplugging the connector and replacing with the new battery pack.

Hardware shall be capable of using power sources that would include commercial power AC or DC power supplies are available to meet the customer's specification.

The system shall have a non-interruptible power source available, including but not limited to batteries, solar panels, thermoelectric generators, etc.

## INSTALLATION FEATURES

The field installed equipment, remote modules shall have color coded analog & digital connectors and color coded function connectors.

The system shall allow access to the unit in the field through a **Smart phone** optimized web access.

## OPERATING TEMPERATURE

The remote modules (modules located in the field) shall have a continuous operating temperature range, even in a secondary enclosure, of **-40 Celsius to +85 Celsius** (-40 Fahrenheit to +185 Fahrenheit), and to withstand humidity levels in the range of 0 to 95% without condensation.

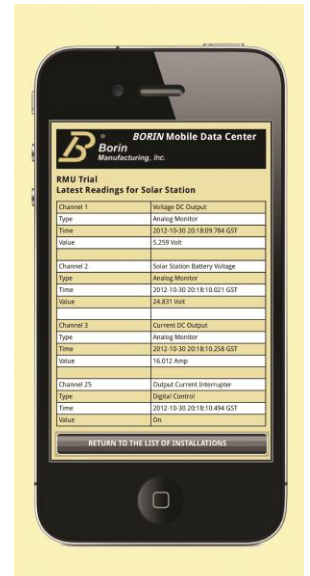

## COMMUNICATIONS

### COMMUNICATIONS FORMATS

The system shall work with a broad range of communication formats which all shall work together seamlessly in any combination and will include the following systems:

- GSM Cellular Network
- Satellite

Other communication systems available are:

- TCP/IP network (Ethernet)
- Radio
- Fiber Optic
- Microwave
- SCADA
- MODBUS
- Et cetera

## INSTALLATION

Installation of the entire system, software and hardware, shall be performed by a trained field technician.